

An Introduction To

**MRT**

MUSCLE RESPONSE TESTING

**YOUR BODY DOESN'T LIE!**

“I will praise thee; for I am fearfully and wonderfully made:marvelous are thy works; and that my soul knoweth right well.” Psalms 139:14

Note to reader: This article is not intended to prescribe or diagnose in any way. It is not meant to be a substitute for professional help. Those who are sick should consult a holistic doctor. Neither the author nor the publisher directly nor indirectly dispenses medical advice or prescribes. The author and the publisher assume no responsibility if you prescribe for yourself without your doctor's approval.

First, let us start off with the fact that everything is full of energy. Everything in the universe is made of atoms and atoms are made of a mix of positive and negative energy held in balance by a concentrated neutral core. Everything is full of energy.

Inner thoughts, Emotions and Written or Spoken words also have energy and a vibrational rate which affects everything in the environment and sometimes more.

The Bible says, **“And Jesus, knowing their thoughts said, `Wherefore think ye evil in your hearts?’” (Matthew 9:4).** That is an actual example of one person’s inner being sensing the thoughts or feelings of another’s inner being. Often you can walk into a room and sense the energy vibrations (**“feel the vibes”**) of the occupants.

A lie detector test or polygraph is a simple feedback device. If a subject answers a statement truthfully, his body remains calm. However, if his answer contains a lie, his body automatically reacts. The discord within his body caused by a lack of truth can be measured with a polygraph machine on a sheet of paper. Truth and untruth do cause definite physiological responses within the body. Truth produces a positive energy and lies produce a negative energy.

Music and sound is a combination of frequency and vibration within a range that our ears were designed to be sensitive to. An interesting note is that symphony conductors have the longest life span of any occupation. I wonder if it is because of the healing quality of the vibrations in which they are constantly immersed. **King David understood this and had worshipers continuously in the temple.**

**Perhaps, like me, you need to learn more about vibrations, frequency, and energy in order to understand how they can affect the body.**

## What is Muscle Response Testing (MRT)

MRT comes from a branch of study called **“Applied Kinesiology”**. The word kinesiology comes from two Greek words, **“kinesis”** meaning **“motion”**, and **“ology”** meaning **“the study of”**. Kinesiology, then, means **the study of the principles related to human motion.**

The term **“applied”** according to Webster is **“put to practical use”**. So **“applied kinesiology”** is **the practical application of the principles of body movement.** This is what muscle response testing is all about.

Applied kinesiology is a system which uses the patient’s body as a laboratory of investigation. The response of the body is unerring. The body never lies. Applied Kinesiology was introduced in the United States by George J. Goodhart, Jr., D.C., in Detroit, Michigan in 1964, and has grown rapidly ever since.

### How trustworthy is MRT?

A great degree of accuracy and reproducibility appears to be present in muscle response testing when done by individuals knowledgeable in the science and proficient in its art. Some types of muscle response tests are more accurate than others. Quantum Reflex Analysis is the most reproducible and accurate muscle response test that we have found to date.

Alfred Scoop evaluated the reproducibility of muscle testing using a hand-held dynamometer, with six trained examiners testing ten naive subjects. The correlation between examiners was 91%, which is a high degree of accuracy.

[Alfred L. Scoop, “An Experimental Evaluation of Kinesiology in Allergy and Deficiency Disease Diagnosis,” *Journal of Orthomolecular Psychiatry*, Vol. VI, No. 2 (1978)]



# WHAT MAKES MRT WORK?

Definition: Muscle Response Testing (MRT) is a way of checking the energy flow within your body to discover what organ(s) are under stress and need nutritional support and what kind of support they need.

First, we will examine a scientific basis for it, exploring four premises which are foundational to the practice of Muscle Response Testing.

We will cover atoms, electrons, electricity, and magnetism, and see how these relate to the practice of Muscle Response Testing. We will take the time to quote rather extensively from a recognized source of knowledge, the Worldbook Encyclopedia, to help satisfy our questioning and sometimes unbelieving minds.

We want to nail this phenomenon down as clearly and authoritatively as we can from a scientific worldview.

We will then go on to lay out a biblical and spiritual foundation for Muscle Response Testing and the use of supplements and herbs. We will leave no doubt concerning the fact that Muscle Response Testing falls well within the confines of biblical and spiritual principles.

## MUSCLE RESPONSE TESTING IS BUILT UPON FOUR PREMISES:

### PREMISE ONE:

Your mind, which oversees countless bodily functions every minute of every day, knows what is good for your body and what is not. One hundred trillion impulses per second travel between your mind and body. Obviously, you are not aware of most of these. They are operating on the subconscious level.

For example: Your mind monitors every single detail of your body's systems, regulating organs, glands, respiratory rate, heart rate, swallowing, blinking, water level in the body, digestion, etc.

### PREMISE TWO:

Your mind communicates with your body continuously through electrical (**biomagnetic**) energy flowing through your nervous system.

*For example: When a medical doctor performs an electrocardiogram, he connects metal strips to the patient. These conduct electricity to the electrocardiograph, which in turn amplifies the currents and records them on paper or a computer monitor as a series of wavy lines. This is a record of the electrical currents which control the patient's heart muscles.*

An electroencephalograph is an instrument used to measure and record the electrical voltages produced by neurons (nerve cells) in the brain. A recording of this electrical activity is called an electroencephalogram (EEG). It is performed by medical doctors by attaching electrodes to the patient's scalp.



**Your nervous system**  
transmits one hundred trillion  
impulses per second

The current theory on this electrical energy is: Biomagnetic energy is the flow of positively charged ions flowing through one's nerve cells.

See World Book Encyclopedia under "Nervous System" for more detail on this process.

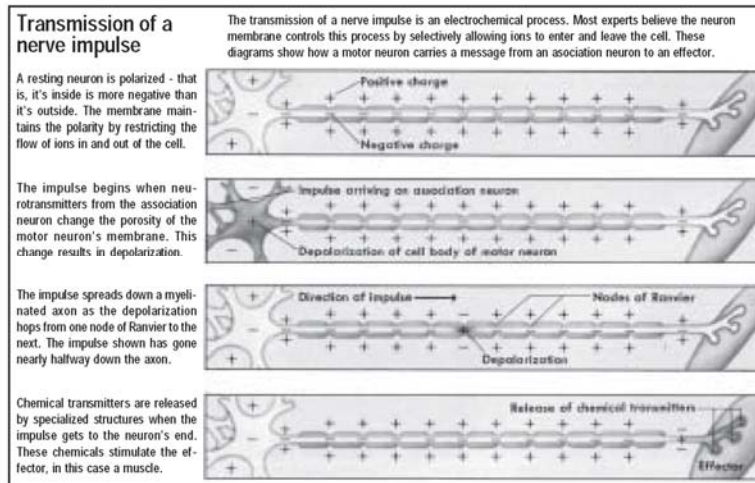

Source: World Book Encyclopedia, vol. 14, p. 135

### PREMISE THREE:

The sensors of your body can pick up, and respond to sensations (vibrations, frequencies) even ones that we are not consciously aware of.

*For example: The nerves near the skin of your body can detect the vibrations of any substance or person that comes near your body, and communicates this information back to your brain.*

When you stop to think about it, most of us can sense the “**vibes**” in the air when we walk into a room. There are certain people with whom we feel “**in sync**” and have instant rapport, and then there are the people with whom we feel “**out of sync**” or can't stand to be around, even if they don't say or do anything.

This is due in part to our mind and body's ability to sense these unseen vibrations or energy and respond to them even when we are not consciously aware of them. (Matt. 9:4).

### PREMISE FOUR:

MRT gives your mind a method of communicating what it knows back to you.

*For example: We have been told that we use less than 10% of our brains. Muscle Response Testing gives the other 90% of your brain a way to communicate to you what it knows (much of this knowledge is on a subconscious level).*

The art of muscle testing is like a computer programming skill with a more sophisticated computer than any man could ever invent.

## THE VALUE OF MUSCLE TESTING:

1. MRT is the easiest way available to customize a nutritional program for a specific individual's needs at any specific point in time. If your body starts to weaken, MRT will tell you about it long before you experience functional breakdown of an organ. If you have already experienced a breakdown in your body, MRT can show you what you must do so your body's healing resources can speed you on the way to recovery. The five stages of progression in a nutrient deficiency are:
  - a) Nutrient reserves in the body are depleted,
  - b) There is a depletion of the nutrient from the body's tissues,

- c) The depletion causes bio-chemical changes which can be detected in the blood or urine,
  - d) Depletion causes functional changes which are manifest as symptoms: fatigue, gas, distress, lack of concentration,
  - e) Depletion causes anatomical changes which include changes in skin, skeleton, tongue and other parts of the body. Most Doctors begin to diagnose at level five. MRT can discover deficiencies at level one.
2. MRT involves the “patient” in the healing process, allowing you to take a greater degree of responsibility for your own health. Many times we don’t know exactly what to do to help our bodies get well. Through MRT, you will always know exactly what your body wants you to do to assist it in the healing processes.
  3. Muscle testing helps enhance the placebo effect, and a positive use of the placebo effect enhances one’s recovery. Because the client has felt his muscle become strong when the right nutrient is put in his hand, he has an intuitive belief within him that this nutrient will help his body. This faith and belief aids in the healing process. The Bible says, **“According to your faith, be it unto you.”** Faith is a powerful force in promoting health, just as fear is a powerful force in promoting sickness. **“For the thing which I greatly feared is come upon me, and that which I was afraid of is come unto me” (Job 3:25).**

## **SOME SCIENTIFIC BACKGROUND ON ATOMS, ELECTRICITY, AND MAGNETISM AS THEY RELATE TO MUSCLE RESPONSE TESTING**

Most of us need to review a bit of high school science in order to restore a basic understanding of the “laws” of science which will help us understand how and why we can put a container of product in our hands and our bodies can instantly identify and respond to it. The facts we need to review are:

- 1) Everything is made of atoms which contain electrons.
- 2) Electricity is the movement of electrons or ions (which are charged atoms).
- 3) Electricity creates a magnetic field.
- 4) Through induction, this magnetic field can influence objects nearby.

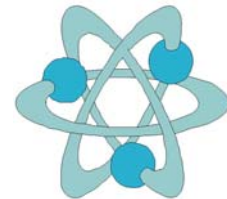

Everything around us is  
made up of atoms

With this foundation, Muscle Response Testing will make sense. In the sections below, we will quote heavily from the Worldbook Encyclopedia, as most people will recognize this as a scholarly source of unbiased information.

### **EVERYTHING IS MADE OF ATOMS WHICH CONTAIN ELECTRONS.**

Related MRT Thesis: Any supplement we put in our hand has an electrical base and an atomic structure which vibrates at its own unique frequency or frequencies. This frequency can be sensed by the nerves of our body and registered as something which strengthens or weakens us. The Worldbook Encyclopedia tells us that:

“Everything around us consists of atoms. Atoms, in turn, are made of three main types of tiny particles: electrons, protons, and neutrons. Both electrons and proton have an electric charge. An electron has one unit of negative charge, and a proton has one unit of positive charge. A neutron has no charge. Protons and neutrons are heavier than electrons and are crowded into the nucleus, the central core of an atom. Electrons whirl around the nucleus.” (Vol. 6 p 189).

Einstein demonstrated that at the core of all matter we find energy. He did this with his famous formula,  $E = MC^2$  (energy equals mass times the speed of light squared). Mathematical laws tell us that  $M = E / C^2$  (mass equals energy divided by the speed of light squared) is therefore also true, allowing us to define matter in terms of energy.

So energy is at the core of our universe and at the core of all matter. Every element, nutrient, color, and

word vibrates at its own specific frequency. Our body can readily identify any object placed against its skin or any color placed before its eyes or any word that comes to its ears according to its unique frequency. And our brain, being in constant contact with, and control over, every single aspect of the body, can discern whether the object or color or word or energy will strengthen or weaken the body's processes. This is generally done on a sub-conscious level.

“Quantum mechanics goes beyond the limits of classical physics, which is based on the laws formulated by the English scientist Sir Isaac Newton. It ranks as one of the major scientific achievements of the 1900's. Quantum mechanics has contributed greatly to the development of such important devices as lasers and transistors. It also has enabled scientists to gain a better understanding of chemical bonds and chemical reactions.”

## Understanding quantum mechanics.

In an atom, tiny particles of negative electrical charge called electrons move in orbits around a nucleus of positive charge. Quantum mechanics shows that the electrons can move only in certain orbits. Each orbit, called a quantized orbit, has a particular value of energy. When an electron is in a given orbit, it exists at a specific energy level and does not release or absorb energy. An electron remains in this normal state as long as its atom is not disturbed. But if outside forces act on the atom, the electron can change to another quantized orbit.

**“When an electron jumps from an orbit of higher energy to one of lower energy, it gives off energy as light. This light is released in the form of a tiny bundle of energy called a quantum or photon....”** Scientists once believed light was a wave emitted as a continuous flow. But quantum mechanics explains that light is a stream of separate photons, which have characteristics of both particles and waves.

A photon behaves like a particle because it occupies a fixed amount of space. A photon also behaves like a wave because it has a definite frequency (number of vibrations per second), which is proportional to its energy. “A photon's frequency forms a single spectrum line that represents a particular wavelength or color.

The atoms of a chemical element give off photons of a wide range of frequencies to produce many different lines. This series of lines makes up the chemical element's spectrum, which differs from that of any other element. The frequencies of an element's spectrum line can be calculated by using quantum mechanics. **“Quantum mechanics shows that electrons and other atomic particles of matter are also associated with waves. These waves, called matter waves, have a specific wavelength.”** (Vol. 16 p. 6)

So science helps us understand that when we place an item in our hand when muscle testing, that item contains energy with a specific wavelength or frequency. The body senses this frequency and responds to it, becoming stronger or weaker depending on whether it is a frequency the body needs or doesn't need.

## ELECTRICITY IS THE MOVEMENT OF ELECTRONS OR IONS (WHICH ARE CHARGED ATOMS).

“Ordinarily, an atom has an equal number of electrons and protons, and so it is electrically neutral. If an atom gains some electrons, it becomes negatively charged. If an atom loses some electrons, it becomes positively charged. Atoms that have an electric charge - **either negative or positive** - are called ions.” (Vol. 6 p.189). Since there are electrons within all nutrients, nutrients are, at their core, energy with varying frequencies.

## ELECTRICITY CREATES A MAGNETIC FIELD.

“Every charged particle is surrounded by an electric field, the space around the particle in which the charge has an effect.” (Vol. 6 p. 189)

**Magnetism.** Electric current in a wire creates a magnetic field around the wire. If the wire is run through a sheet of cardboard on which iron filings have been sprinkled, the filings will form a series of circles outlining the field.

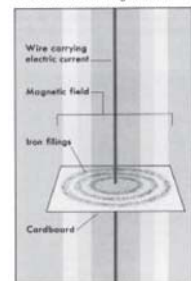

Source: World Book Encyclopedia, vol. 6, p. 193

“The region around a magnet, where the force of magnetism can be felt, is called a magnetic field. A conductor carrying electricity is always surrounded by a magnetic field.” (Vol. 6 p.193).

Since the core of elements is electrical energy, every element (i.e. food, herb, supplement) creates its own minute magnetic field which can be measured and which extends out as small distance from the element.

### **THROUGH INDUCTION, THIS MAGNETIC FIELD CAN INFLUENCE OBJECTS NEARBY.**

“Charged particles exert a force on one another, even when not in physical contact, because of their electric fields. For example, ions with unlike charges attract one another, and those with like charges repel one another.” Electricity is sometimes classified as static electricity or current electricity, but both are actually made up of the same kinds of particles. Static electricity consists of electrons or ions that do not move. Current electricity is made up of moving electrons or ions. Almost all of the electricity we use is current electricity.

“You can generate static electricity by combing your hair briskly on a dry day. Your hair loses electrons and becomes positively charged. The comb gains electrons and becomes negatively charged....” An object that has a stationary electric charge can charge another object by either contact or induction...**Charging by induction occurs when a charged object is placed near - but does not touch - another object.**

Suppose a positively charged glass rod is placed near an insulated metal ball. The rod will pull electrons in the ball to the side of the ball nearest the rod. The opposite side of the metal ball will then have a positive charge and will attract negatively charged particles.” (Vol. 6 p. 189-191).

It is because of the principle of induction that your cassette player works when you plug it into your 110volt wall socket. Through induction, the cassette player transformer reduces the 110 volts down to the 12 volts the cassette player can use. A transformer works in the following way: The incoming electrical wire passes through a coil, inducing an increased magnetic field, and then returns to the wall socket. A second wire coil is adjacent to (but not touching) the first wire coil in the transformer and through induction, the second coil generates a current from the magnetic field of the first coil, which is used to operate the cassette recorder. The ratio of the number of coils of wire in each coil determines the voltage and thus the current that comes out of the other side of a transformer.

**See the diagram below.**

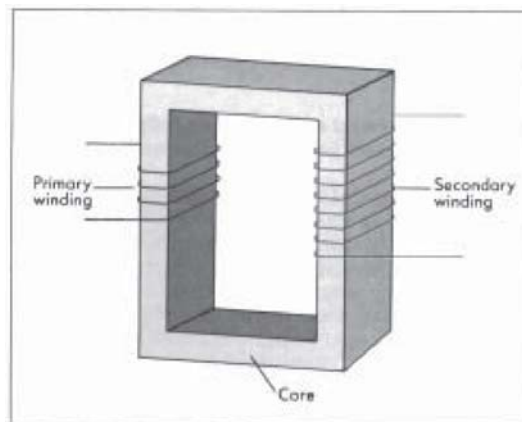

Source: World Book Encyclopedia, vol. 19, p. 372

When you hold a product in your hand for MRT, even if it is in a plastic or glass container, it emits an energy field which, through induction, interacts with the nerves in your hand (or any part of your body in contact with the container of product). The nerves transmit the frequency induced through the container to your brain and within a split second, your brain has made the decision that this frequency will either strengthen or weaken your muscles. This conclusion is demonstrated by experiencing strengthened or weakened muscles throughout your body.

If you place some small metal ball bearings on a glass or plastic plate and move a magnet around under the plate, you will, of course, observe that the ball bearings move also. Similarly, herbs and products in plastic bottles, when placed in one's hand, emit an energy field which can be sensed by the nerves in your hand, even through the bottle.

If you consider the positive and negative poles of a magnet, you will remember that like charges repel and unlike charges attract. Careful observation has taught us that the bottoms of the feet and the palms of the hands are negative. The tops of the feet, the tops of the hands, and the top of the head are positive. You stand on the crust of the earth, which is positive. Thus it makes sense that when you walk barefoot on the earth, you should feel energized because the bottoms of your feet (negative charge) are walking on a positively charged earth. The charge pushes you up and onward.

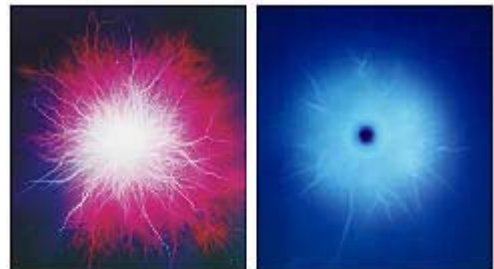

This gives you a basic scientific understanding of how and why Muscle Response Testing works.

### **WHAT HAPPENS WHEN YOU TOUCH A MUSCLE RESPONSE TEST POINT ON YOUR BODY?**

With muscle testing, you can touch many different specific areas of the body to determine the energy flow in that area of the body. When you use the strategy of touching a Muscle Response Test point on your body, you connect with the energy field in that particular area of your body, and your body gives you a response based on how that particular organ is doing, whether it is stressed or normal. If it is stressed and receiving an extra shot of energy to keep it going, when you add your energy to the field (by touching it), it **“blows the circuits”** and the arm goes weak, giving the signal that this particular organ is under stress. If the organ is not stressed, the addition of your extra energy will not be enough to “blow its circuits” and the arm will remain strong, giving you a signal that the organ is doing fine. It is also true that your body is a magnet. We already know that the body has electricity flowing through it. That is why doctors can perform EKG's successfully. We also know that electrical flow produces a magnetic field. So we have a weak magnetic energy field around us which can be probed and tested. There are even instruments available which can and do measure this weak energy field.

Kerlian photography can photograph this field. The painters of the Middle Ages often saw this field and recreated it as halos around the heads of saints. Many in the Western culture have lost their sensitivity to these spiritual phenomenon.

### **FREQUENCIES AND BODILY ORGANS**

Every organ or gland in your body contains a concentration of a particular mineral or nutrient. This mineral concentration gives every organ and gland in your body its own specific rate of vibration or frequency. For example:

- \*the thyroid is an iodine organ
- \*the heart is a potassium organ
- \*the stomach is a sodium organ
- \*the liver is an iron organ
- \*the prostate is a zinc organ
- \*etc.

God has designed all these bodily organs to play together in a wonderful orchestration, each organ be-

ing tuned to its own frequency. If the thyroid gets out of tune, you have a thyroid problem. Iodine retunes the thyroid to the proper frequency (i.e. the frequency of iodine), thus restoring its function. Iodine normalizes the thyroid. If the thyroid frequency is too fast, it tunes it down. If it is too slow, it tunes it up. In this way, foods and the nutrients in them restore your body to health. The person with a thyroid problem would therefore want to feed his body a plant which is high in iodine, such as kelp, dulse, or black walnut. He could grow his own herbs, but most of our lives are a bit too busy for that. Therefore, rather than our needing to go to the field to pick the plant, the plant has been harvested by an herb company, put into a capsule, and made ready for purchase. That makes it easier for most of us to get restorative quantities of quality nutritional substances into our bodies.

Man was made from the dust (elements) of the ground. The plants which grow, soaking up the elements of the ground, retune the organs in our bodies to their proper frequencies.

The Bible says "He causeth the grass to grow for the cattle and herbs for the service of humanity" Psalms 104:14 KJV.

It often takes about three months to restore a deficiency, although you may experience some symptomatic relief within a few days or weeks. You should expect to add an extra month for healing for every year you have been sick. Herbs work slower than pharmaceutical medicines (which are often derivatives of herbs). The herbs God has given us are food and are non-toxic.

## **BIBLICAL PRINCIPLES WHICH RELATE TO MUSCLE TESTING**

Now let us gain a biblical/spiritual understanding of the principles involved in the practice of muscle testing, and become comfortable that the phenomenon of MRT clearly falls within a biblical framework. Recalling what we have already learned from science about the wonder and marvel of God's creation, let's examine Scripture.

God spoke the worlds into being. All matter came originally from spiritual energy. Therefore spiritual energy is the foundation of matter. This corresponds exactly with what quantum physics has discovered.

*"And God said, 'Let there be light:' and there was light." Genesis 1:3*

*"And God said, 'Let there be a firmament in the midst of the waters, and let it divide the waters from the waters.'" Genesis 1:6*

*"And God said, 'Let the waters under the heaven be gathered together unto one place, and let the dry land appear:' and it was so." Genesis 1:9*

*Mmmmm,,,,,,,,,,,,,,,,,,,,,,,,,,,,,,,,,,,,,*

*"Who being the brightness of His glory, and the express image of His person, and upholding all things by the word of His power, when He had by Himself purged our sins, sat down on the right hand of the Majesty on high;" Hebrews 1:3*

Man is created from the dust of the earth. This dust is made up of the atoms which are held together by God's energy.

*"And the LORD God formed man of the dust of the ground..."Genesis 2:7*

God gave man the herbs of the earth to sustain himself. Those foods and herbs which grow from the soil bring with them nutrients from the soil which strengthen and restore the organs of the body.

*"And God said, 'Behold, I have given you every herb bearing seed, which is upon the face of all the earth, and every tree, in the which is the fruit of a tree yielding seed; to you it shall be for meat.'" Gene-*

sis 1:29

*"...and the fruit thereof shall be for meat, and the leaf thereof for medicine." Ezekiel 47:12*

God breathed into man the breath of life and man became a living soul. So mankind has an additional energy from God. God is Spirit, and He has created mankind with a spirit also.

*"...and breathed into his nostrils the breath of life; and man became a living soul." Genesis 2:7*

**At the point of salvation, man's spirit is renewed and indwelt by the Holy Spirit, which invigorates man's whole being: spirit, soul, and body.**

*"Then Peter said unto them, "Repent, and be baptized every one of you in the name of Jesus Christ for the remission of sins, and ye shall receive the gift of the Holy Ghost." Acts 2:38*

*"But he that is joined unto the Lord is one spirit." 1 Corinthians 6:17*

God has made healing power available to the Church through the laying on of hands. This extra dose of spiritual energy can and does restore the spirit, soul, and body of man. It is wise for one involved in the healing profession to lay hands on people and pray for them to be healed when they are sick. When operating in the healing anointing of the Holy Spirit, additional amounts of energy flow through one's body and out into others whom you touch.

Jesus could sense the energy flow of the Spirit of God as it was released to others. We, too, if we become sensitive, can sense the energy flow within our own bodies and to others' bodies. Often it is sensed as warmth, heat, and vibration in the hands. Tune to intuition when you lay hands on people and pray for them and see if you don't sense these things.

*"Jesus asked, "Who touched me?" He had noted that virtue (i.e. power) had flowed from Him. "And Jesus, immediately knowing in himself that virtue had gone out of him, turned him about in the press, and said, "Who touched my clothes?" And his disciples said unto him, Thou seest the multitude thronging thee, and sayest thou, "Who touched me?" Mark 5:30,31*

## **AN EXAMINATION OF THE WORDS FOR "POWER" IN THE NEW TESTAMENT**

1. There are three words translated as "power" in the New Testament. *Energes* is very interesting in light of our discussion. *Exousia* (used 108 times) means "right or prerogative" *Dunamis* (used 118 times) means "might or power" *Energes* (used 31 times) means "active energy"
2. Following is an example of *energes* as active energy within a person. The word translated from *energesis* bold in the following verse.

*"Whereunto I also labour, striving according to his **working**, which worketh in me mightily." Colossians 1:29*

3. When one is anointed for ministry, he has increased energy rubbed into his being. The Hebrew word for "anointing" is *mischah* which means "smearing". The Greek word for "anointing" is *ischarisma* which means "a rubbing in". There is a tangible impartation of the substance of the anointing upon a person when he is anointed. Elisha's bones had so much anointing rubbed into them that when a dead man touched Elisha's dead bones, the dead man was resurrected (2 Kings 13:21)!
4. The ministry of healing is to involve laying on of hands, which allows the healing energy of God to flow into the sick person.

**"They shall take up serpents; and if they drink any deadly thing, it shall not hurt them; they shall lay hands on the sick, and they shall recover." Mark 16:18**

5. Energy can be passed even into inanimate objects.

*"Handkerchiefs or aprons were carried away from Paul's body to the sick, and the diseases left them and the evil spirits went out." Acts 19:12*

Even Peter's shadow conveyed healing power (Acts 5:15). (Note: Spiritual energy seems to be similar to electrical energy in that an item can carry a charge [i.e. static electricity] which can be released upon touch.)

## **THE BIBLE SPEAKS CONCERNING THE POWER IN THE RIGHT HAND**

*"Thy right hand, O LORD, is become glorious in power: thy right hand, O LORD, hath dashed in pieces the enemy." Exodus 15:6*

*"And of the rest of the oil that is in his hand shall the priest put upon the tip of the right ear of him that is to be cleansed, and upon the thumb of his right hand, and upon the great toe of his right foot, upon the blood of the trespass offering." Leviticus 14:17*

*"I have set the LORD always before me: because He is at my right hand, I shall not be moved." Psalms 16:8*

*"The LORD is thy keeper: the LORD is thy shade upon thy right hand." Psalms 121:5"*

*A wise man's heart is at his right hand; but a fool's heart at his left." Ecclesiastes 10:2*

*"For I the LORD thy God will hold thy right hand, saying unto thee, Fear not; I will help thee." Isaiah 41:13*

*"Mine hand also hath laid the foundation of the earth, and my right hand hath spanned the heavens: when I call unto them, they stand up together."*

*"Jesus saith unto him, Thou hast said: nevertheless I say unto you, Hereafter shall ye see the Son of man sitting on the right hand of power, and coming in the clouds of heaven." Matthew 26:64*

*"For David speaketh concerning him, I foresaw the Lord always before my face, for he is on my right hand, that I should not be moved." Acts 2:25*

*(Also see Gen. 48:14-18; Psalms 20:6; Psalms 48:10; Psalms 98:1; Psalms 110:1; Psalms 118:15; Isaiah 62:8; Matthew 25:33; Acts 3:7; Acts 5:31; Acts 7:55; Romans 8:34; Colossians 3:1; Hebrews 1:13; Hebrews 8:1; 1Peter 3:22; Revelation 1:16; Revelation 1:17.)*

## **THE AWESOME POWER OF WORDS UPON OUR BODIES**

*"Death and life are in the power of the tongue." Proverbs 18:21*

1. "For as he thinketh in his heart, so is he" (Proverbs 23:7).

The words we think within our minds send a message to every cell in our bodies, creating for us what we have spoken in our hearts. This shows the awesome power of words, even when thought quietly within our hearts. Our whole being hears them and is affected by them, either for good or for bad.

2. "Beloved, I pray that in all respects you may prosper and be in good health, just as your soul prospers" (3 John 2). In this verse, outer, physical health is clearly connected to the health of our souls (i.e. mind, will, and emotions). So again we see that the thoughts we think affect our bodies.

3. "And Jesus, knowing their thoughts said, `Wherefore think ye evil in your hearts?'" (Matthew 9:4).

This refers to a phenomenon which many of you have probably experienced in your lives. You come into the presence of a person, and you have a sense of what they are thinking. You just feel it. Your inner man senses their inner man. It “reads” what is going on, and you are inwardly aware of their thoughts.

We know that Jesus laid aside his divine powers when he became a man (kenosis passage: Phil. 2:5-8), so this was not a “special” ability He had because He was the Son of God. I believe God has designed us with this wonderful ability to sense, even though the Western world knows little about it at this time. I also believe God wants to overlay this natural ability with His gifts, such as a word of wisdom and a word of knowledge. Satan, too, wants to overlay it with various psychic phenomena, so we must be careful to present ourselves to God, and stay within realms God has allowed us to operate in. (i.e. Stay away from fortune telling, witchcraft, astrology, and other forbidden psychic phenomena).

Therefore, based on the biblical text, we see that we can sense each others’ hearts. Most of us have already experienced this phenomenon. Mothers instinctively know when their children are in danger and begin praying for them. When you walk into a room, your heart senses the “vibes”, and sensitive people may even sense what the people have been discussing.

### **IS MUSCLE TESTING EVIL???**

Occasionally you will hear the charge that muscle testing is evil, New Age, or witchcraft. In answering this charge, we need to ask, “What methodology does the person making the accusation use for discovering truth, and did he apply his methodology to this specific issue before making his negative claim?”

Some people’s approach is, “If it is outside of my knowledge base, then it must be evil...”

### **THE BIBLE TEACHES AN APPROACH FOR DISCOVERING TRUTH**

It has been called “The Leaders’ Paradigm” because those who follow this process which God has ordained are led by God into the fulfillment of His purposes in their lives. God’s purposes for us involve leadership (Deut. 28:12-13). The Leaders’ Paradigm is built on the following six pillars. It allows the Holy Spirit to reveal truth to us using six different approaches. It is built upon the conviction that the Holy Spirit is the Teacher in our lives (Jn. 14:10,16,17,21; 1 John 3:20,27).

***Pillar One — Illumined Scriptures (Luke 24:32)*** This pillar is experienced as the Holy Spirit illumines Scriptures to us — we sense them leaping off the page or just coming to our attention spontaneously.

***Pillar Two — Illumined Thoughts in One’s Mind (Luke 1:3)*** This pillar is experienced as the Holy Spirit guides our reasoning processes through spontaneous impressions. It is obvious that Luke’s gospel was more than simply investigative research of his own mind, as what he wrote has stood as the Word of God for 2000 years.

***Pillar Three — Illumined Witness in One’s Heart (Mark 2:8)*** Deep inner peace or unrest is often part of this experience.

***Pillar Four — Illumined Counsel of Others (Prov.11:14)*** This pillar is experienced as one asks his/her spiritual advisors to seek God for confirmation, additions, or adjustments in the guidance he senses God has given him.

***Pillar Five — Illumined Understanding of Life’s Experiences (Matt. 7:16)*** This pillar is experienced as one asks God to give him insight and understanding concerning the fruit life is demonstrating. God gives him revelation as to what has caused the fruit.

**Pillar Six — Illumined Revelation from God Through Dreams, Visions, Prophecy, and Journaling (Acts 2:17)** This pillar is experienced as you receive direct revelation from God through dreams, visions, and journaling. Journaling is the writing out of your prayers and God's answers.

The wise leader has a solid foundation of Scripture within him which underlies the use of these six pillars and has a goal of glorifying God in all he does. He looks for all six of the pillars to line up before he assumes a direction.

I think we all need to beware of any levels of phariseeism within ourselves. Pharisees do not use the Leaders' Paradigm. They do not depend on the Holy Spirit in their process for discovering truth. They ignore the Holy Spirit and live out of Biblical Law ONLY, rather than out of the Word and the Spirit as Jesus did (Jn.5:19,20,30).

You will recall that the Pharisees always stoned the prophets (Acts 7:52) and even killed Jesus. Not that the Pharisees did not love God. They did. They thought they were doing God a favor in killing Jesus. And they loved the Word of God. However, they loved their traditions just a bit too much. And they used their traditions to invalidate portions of the Word of God and to explain why they no longer needed to be kept.

Each of us must examine our lives diligently to be sure we have not fallen into the trap of becoming a modern day Pharisee. The Bible is crystal clear that the Christian is to live and walk in the Spirit (Gal. 5:25), to pray in the Spirit (Jude 20), to be filled with the Spirit (Eph. 5:18), and to worship in spirit (Jn. 4:23).

The Spirit is that inner, energizing force which is not matter. He is a Person whose Presence is felt as a spiritual energy which is sometimes referred to as the anointing. To reduce life to matter alone is to remove the power of the Holy Spirit from the experiences of life and to focus on the worship of the false gods of our culture —rationalism, humanism, and a mechanistic approach to the universe rather than a vitalistic one.

The Bible (Col.1:17) and the most up-to-date science ( $E = MC^2$ ) both confirm that energy is at the core of the universe. The energy of God holds this universe together (Col.1:17).

## **STANDARDS FOR JUDGING WHICH THE FEARFUL USE AND WHICH ARE NOT TAUGHT IN SCRIPTURE:**

1. **HEATHENS DO IT, SO IT MUST BE BAD.** God rains on the just AND THE UNJUST (Matt 5:45). Moses received wise counsel from his father-in-law Jethro, a heathen, and acted upon it (Exodus 18). Daniel spent three years being trained in Nebuchadnezzar's court, learning the "literature and the language of the Chaldeans" (Dan. 1:4) and yet "God gave [him] knowledge and intelligence in every branch of literature and wisdom; Daniel even understood all kinds of visions and dreams" (Dan. 1:17). God can overlay your learning with an anointing of the Holy Spirit and help you see things others don't see. This will cause your superiors to be impressed with your knowledge and performance (Dan. 1:19).
2. **IT IS EASTERN, SO IT MUST BE BAD.** Jesus was not a Westerner.
3. **IT INVOLVES SPIRITUAL ENCOUNTER, SO IT MUST BE BAD.** The Bible is full of spirit encounter from Genesis to Revelation.
4. **IT IS NEW AND DIFFERENT, SO IT MUST BE BAD.** The only constant is change. Nowhere does the Bible teach that new is necessarily evil. "*Behold, I will do a new thing; now it shall spring forth; shall ye not know it?*" (Isaiah 43:19). Jesus even said to His disciples, "*I have yet many things to say unto you, but ye cannot bear them now*" (John 16:12).
5. **I DON'T UNDERSTAND IT, SO IT MUST BE BAD.** "*Trust in the LORD with all thine heart; and lean not unto thine own understanding. In all thy ways acknowledge him, and he shall direct thy paths.*" Proverbs 3:5,6
6. **IF PEOPLE MAKE MONEY FROM THE IDEA, IT MUST BE BAD.** "...the workman is worthy of his

hire.” Matthew 10:10

7. **I AM NOT SURE ABOUT IT, SO I WILL CALL IT EVIL.** *“Woe unto them that call evil good, and good evil; that put darkness for light, and light for darkness; that put bitter for sweet, and sweet for bitter!” Isaiah 5:20* It is a serious sin to call things evil which are not and to call things good which are not, especially if we are teachers and passing our careless “judgments” on to others.

Getting on God’s “woe” list is not a valuable asset in life. It will indeed set one back a good way.

## THE FEARFUL PULL BACK

Fear is a motivating force which satan uses effectively in many people. The Bible makes it abundantly clear that perfect love casts out fear (1 Jn. 4:18). The Spirit-filled Christian will be moved by faith joined with the aggressive commission of Jesus Christ to disciple all nations (Matt. 28:19).

The fearful are afraid of everything new, of every challenge, and of forces around them that they can’t control or understand. In their fear, they generally come against all new ideas, cower at every new challenge, and hide from the powerful forces they assume to be hostile.

## ONLY THOSE WHO SEEK TRUTH FIND TRUTH!

“Blessed are they which do hunger and thirst after righteousness: for they shall be filled.” Matthew 5:6

“Blessed are the pure in heart: for they shall see God.” Matthew 5:8

Some people do not hunger and thirst after righteousness. (Righteousness, of course, embodies truth.) Some hunger and thirst to prove themselves right. Some people do not have a pure heart. Instead they hunger and thirst to prove others wrong.

For example, one gentleman, who was in charge of producing a major “medical” bulletin for a well-known and well-respected evangelical Bible teacher, evaluated modern alternative medical approaches. He offered this comment:

***“I started out to prove that these alternative methods were quackery, and I found out that they were occult.”***

Well, when you start out with the objective of proving someone wrong, you have begun your search with impure motives and your search for truth will not be fulfilled. You have taken an adversarial attitude in your heart. This is strictly forbidden in Scriptures. It is satan who is the adversary and accuser (Matt. 13:39; Rev.12:10,11).

We are not to take on his heart when we search for truth. We are to take on the heart of the Holy Spirit. We are to come along side and comfort (Jn. 14:16,17). When the Bereans heard a NEW teaching, they did not try to prove it wrong; they tried to prove it right (Acts 17:11). Let us be more noble minded, as the Bereans were, and seek to prove people RIGHT, not prove them wrong.

Many people who call themselves “Christians” or “Bible Believers” try to prove that ALL alternative approaches to medicine are false, and that the allopathic approach to medicine used by traditional doctors today and which focuses on the use of drugs is the only “biblical” approach to medicine.

Hopefully these few thoughts will help you in thinking through a Spirit led, Biblical approach for processing new ideas.